



Booklet No. :

EC - 15

Electronics & Communication Engineering

Duration of Test : 2 Hours

Max. Marks : 120

Hall Ticket No.

--	--	--	--	--	--	--	--

Name of the Candidate : _____

Date of Examination : _____ OMR Answer Sheet No. : _____

Signature of the Candidate

Signature of the Invigilator

INSTRUCTIONS

1. This Question Booklet consists of **120** multiple choice objective type questions to be answered in **120** minutes.
2. Every question in this booklet has 4 choices marked (A), (B), (C) and (D) for its answer.
3. Each question carries **one** mark. There are no negative marks for wrong answers.
4. This Booklet consists of **16** pages. Any discrepancy or any defect is found, the same may be informed to the Invigilator for replacement of Booklet.
5. Answer all the questions on the OMR Answer Sheet using **Blue/Black ball point pen only**.
6. Before answering the questions on the OMR Answer Sheet, please read the instructions printed on the OMR sheet carefully.
7. OMR Answer Sheet should be handed over to the Invigilator before leaving the Examination Hall.
8. Calculators, Pagers, Mobile Phones, etc., are not allowed into the Examination Hall.
9. No part of the Booklet should be detached under any circumstances.
10. The seal of the Booklet should be opened only after signal/bell is given.

EC-15-A



ELECTRONICS & COMMUNICATION ENGINEERING (EC)

1. The system of equations $x + 5y + 3z = 0$, $5x + y - pz = 0$ and $x + 2y + pz = 0$ has nontrivial solution if $p =$
(A) 0 (B) 1/2 (C) 2 (D) 1
2. If two eigen values of $A = \begin{bmatrix} 2 & 2 & 1 \\ 1 & 3 & 1 \\ 1 & 2 & 2 \end{bmatrix}$ are 2 and 3 then the third eigen value is
(A) 2 (B) 1 (C) 3 (D) 7
3. The value of $\int_0^{\infty} x^3 e^{-x^2} dx$ is equal to
(A) $\frac{1}{2}$ (B) $\frac{1}{3}$ (C) $\frac{3}{2}$ (D) $\frac{2}{3}$
4. The unit normal to the surface $x^2 + y^2 + 2z^2 = 26$ at the point (2, 2, 3) is
(A) $\frac{1}{\sqrt{186}}(i + 2j + 3k)$ (B) $\frac{1}{\sqrt{176}}(4i + 4j + 12k)$
(C) $4i + 2j + 3k$ (D) $\frac{1}{\sqrt{14}}(i + 2j + 3k)$
5. The integrating factor of the differential equation $(y + xy^2)dx - xdy = 0$ is
(A) $\frac{1}{x^2}$ (B) $\frac{1}{x^2 + y^2}$ (C) $\frac{1}{y}$ (D) $\frac{1}{y^2}$
6. The complete integral of the partial differential equation $z = px + qy + p^2q$ is
(A) $bx + ay + b^2a$ (B) $ax + by + ab^2$ (C) $ax + by + a^2b$ (D) does not exist
7. The residue of the function $f(z) = \frac{z^2}{(z-1)^2(z+2)}$ at the pole $z = 1$ is
(A) $\frac{1}{3}$ (B) $\frac{1}{9}$ (C) $\frac{5}{9}$ (D) $\frac{2}{9}$
8. If the random variable Z has the probability density function $f(z) = \frac{1}{\sqrt{2\pi}} e^{-\frac{1}{2}z^2}$ then the variance of Z is equal to
(A) 0 (B) $\frac{1}{2}$ (C) 2 (D) 1
9. If there is no repetition in the ranks and if $d_i, i = 1, \dots, n$ then the rank correlation is given by
(A) -1 (B) 0 (C) $1 - \frac{\sum d_i^2}{n}$ (D) $1 - \frac{6\sum d_i^2}{n(n^2 + 1)}$

10. Picard's first approximate solution of the initial value problem $\frac{dy}{dx} = x - y$ with $y = 1$ when $x = 0$ is

(A) $1 + x + \frac{x^2}{2}$ (B) $1 - x + \frac{x^2}{2}$ (C) $\frac{x^2}{2}$ (D) $1 + x$

11. Consider the network graph shown in the figure. Which one of the following is NOT a tree of this graph

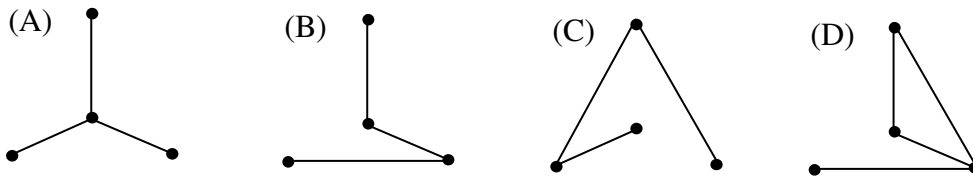
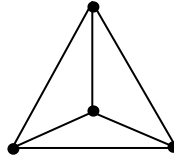

12. In the following circuit the current ' i_1 ' is

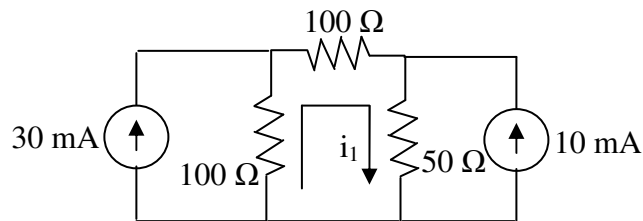

- (A) 10 mA (B) -0.4 mA (C) 0.4 mA (D) -10 mA

13. For the transfer function $\frac{I_o(s)}{I_i(s)} = \frac{s}{s+1}$, If $i_i(t) = 4\delta(t)$ then $i_o(t)$ will be

(A) $[4\delta(t) - e^{-t}u(t)]A$ (B) $[e^{-t}u(t) - \delta(t)]A$
 (C) $[4e^{-t}u(t) - 4\delta(t)]A$ (D) $[4\delta(t) - 4e^{-t}u(t)]A$

14. An independent voltage source in series with impedance $Z_S = R_S + jX_S$ delivers maximum average power to a load impedance Z_L when

(A) $Z_L = R_S + jX_S$ (B) $Z_L = R_S$ (C) $Z_L = jX_S$ (D) $Z_L = R_S - jX_S$

15. In the following circuit the voltage V_a is

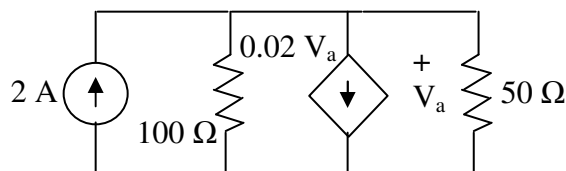

- (A) -40V (B) 32 V (C) 40 V (D) -32 V

16. Consider the circuit shown below

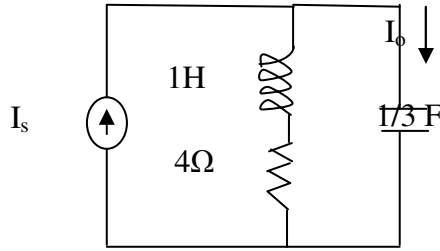

The current ratio transfer function $\frac{I_o}{I_s}$ is

- (A) $\frac{s(s+4)}{s^2+3s+4}$ (B) $\frac{s(s+4)}{(s+1)(s+3)}$
 (C) $\frac{s^2+3s+4}{s(s+4)}$ (D) $\frac{(s+1)(s+3)}{s(s+4)}$

17. A parallel circuit has $R=2\text{ K}\Omega$, $C=50\text{ }\mu\text{F}$ and $L=10\text{ mH}$. The quality factor at resonance is
 (A) 141.42 (B) 70.7 (C) 20 (D) 32.3

18. The h parameters of the circuit shown in figure are

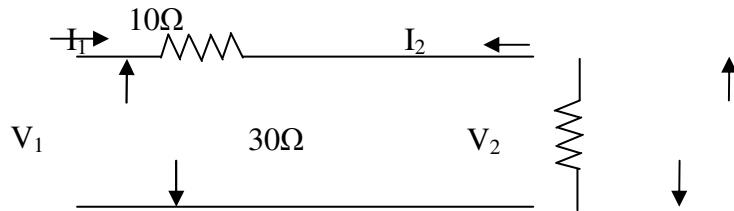

- (A) $\begin{bmatrix} 0.03 & 1 \\ -1 & 10 \end{bmatrix}$ (B) $\begin{bmatrix} 1 & 10 \\ 0.03 & -1 \end{bmatrix}$ (C) $\begin{bmatrix} 0.3 & 1 \\ -1 & 10 \end{bmatrix}$ (D) $\begin{bmatrix} 10 & 1 \\ -1 & 0.03 \end{bmatrix}$

19. The differential equation for the current $i(t)$ in the circuit of the figure is

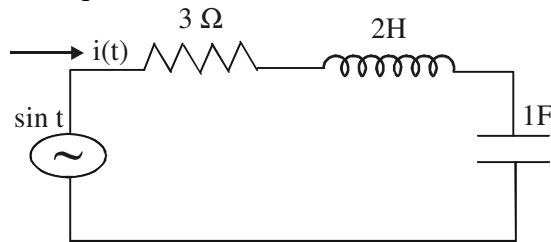

- (A) $2\frac{d^2i(t)}{dt^2} + 3\frac{di(t)}{dt} + i(t) = \cos t$ (B) $\frac{d^2i(t)}{dt^2} + 2\frac{di(t)}{dt} + 3i(t) = \sin t$
 (C) $\frac{d^2i(t)}{dt^2} + 3\frac{di(t)}{dt} + 3i(t) = \cos t$ (D) $2\frac{d^2i(t)}{dt^2} + 3\frac{di(t)}{dt} + i(t) = \sin t$

20. The current in $9\ \Omega$ resistor using superposition theorem is

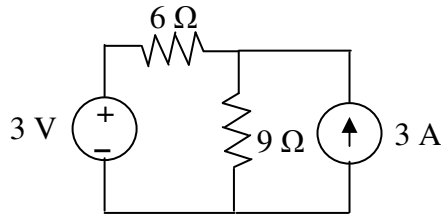

- (A) $-1.4\ \text{A}$ (B) $2\ \text{A}$ (C) $1\ \text{A}$ (D) $1.4\ \text{A}$
21. The condition for the electrical symmetry in the two port network is
 (A) $h_{12} = -h_{21}$ (B) $AD - BC = 1$ (C) $Z_{12} = Z_{21}$ (D) $A = D$
22. In the ac network shown in the figure, the phasor voltage V_{AB} (in volts) is

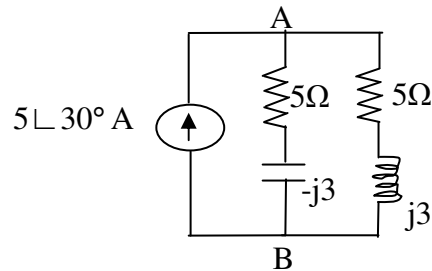

- (A) 0 (B) $5\angle 30^\circ$ (C) $12.5\angle 30^\circ$ (D) $17\angle 30^\circ$
23. A p-n junction diode's dynamic conductance is directly proportional to
 (A) The applied voltage (B) The temperature
 (C) Its current (D) The thermal voltage
24. If $\alpha = 0.981$, $I_{CO} = 6\ \mu\text{A}$ and $I_B = 100\ \mu\text{A}$ for a NPN transistor, then the value of I_C will be
 (A) $2.3\ \text{mA}$ (B) $3.1\ \text{mA}$ (C) $4.6\ \text{mA}$ (D) $5.2\ \text{mA}$
25. In an integrated circuit, the SiO_2 layer provides
 (A) Electrical connection to external circuit (B) Physical strength
 (C) Isolation (D) Conducting path
26. A PIN diode is frequently used as a
 (A) Peak clipper (B) Voltage regulator
 (C) Harmonic regulator (D) Switching diode for frequencies up to 100 MHz range
27. In the monostable multivibrator as shown in Figure, $R=100\ \text{k}\ \Omega$ and the time delay $T=200\ \text{m}\ \text{sec}$. Calculate the value of C .

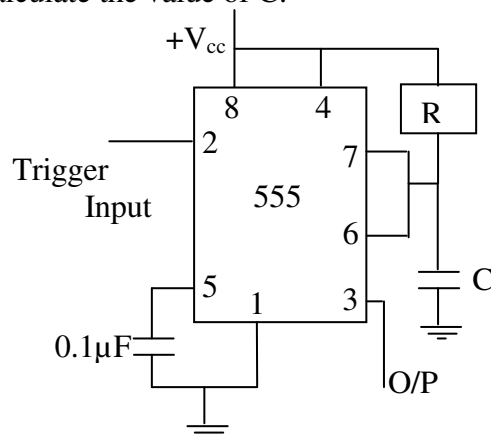

- (A) $8.1\ \mu\text{F}$ (B) $2\ \mu\text{F}$ (C) $3\ \text{mF}$ (D) $1.81\ \mu\text{F}$

28. A diode that has no depletion layers and operates with hot carriers is called ____ diode.
 (A) Schottky (B) Gunn (C) tunnel (D) PIN
29. A LED is basically a _____ p-n junction.
 (A) Forward biased (B) Reverse biased
 (C) Lightly doped (D) Heavily doped
30. For a JFET in the pinch off region as the drain voltage is increased the drain current
 (A) Becomes zero (B) Abruptly decreases
 (C) Abruptly increases (D) Remains constant
31. In the circuit shown below $V_{ref} = 0\text{ V}$, $V_i = 1\text{ V}_{p-p}$ sine wave and saturation voltage of $\pm 12\text{ V}$, determine threshold voltages V_{UT}

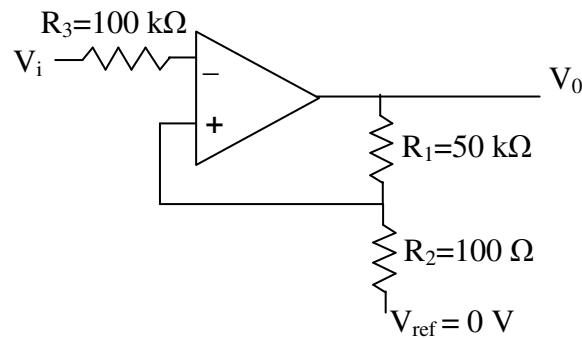

- (A) $V_{UT} = 2\ \mu\text{mV}$ (B) $V_{UT} = -24\ \text{mV}$
 (C) $V_{UT} = 26\ \text{mV}$ (D) $V_{UT} = -26\ \text{mV}$
32. A Hall effect transducer can be used to measure
 (A) Displacement, temperature and magnetic flux
 (B) Displacement, position and velocity
 (C) Position, magnetic flux and pressure
 (D) Displacement, position and magnetic flux
33. For better performance of any regulator, it should have
 (A) Lesser line Regulation (B) High Load Regulation
 (C) Low ripple rejection (D) High ripple rejection
34. In the Circuit shown below if $R_1 = R_2 = R_3 = R = R_F/2$, then find the value of V_0

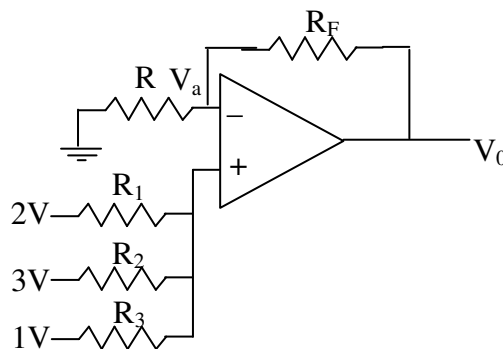

- (A) 7 V (B) 3 V (C) 6 V (D) 8 V

35. In an ideal balanced differential amplifier, the common-mode gain is
 (A) Very Low
 (B) Zero
 (C) Very High
 (D) Double of that of single ended difference amplifier
36. The values of voltage V_D across a tunnel diode corresponding to peak and valley currents are V_P and V_V respectively. The range of tunnel diode voltage V_D for which the slope of its $I-V_D$ characteristics is negative would be
 (A) $V_D < 0$ (B) $0 \leq V_D < V_P$ (C) $V_P \leq V_D < V_V$ (D) $V_D \geq V_V$
37. The voltage gain of a given common source JFET amplifier depends on its
 (A) Input impedance (B) Amplification factor
 (C) Dynamic drain resistance (D) Drain load resistance
38. The 'pinch-off' voltage of a JFET is 5 V. Its "cut-off" voltage is
 (A) $(5.0)^{1/2}$ V (B) 2.5 V (C) 5.0 V (D) $(5.0)^{3/2}$ V
39. A transistor has a current gain of 0.99 in the CB mode. Its current gain in the CC mode is
 (A) 100 (B) 99 (C) 1.01 (D) 0.99
40. MOSFET can be used as a
 (A) Current controlled capacitor (B) Voltage controlled capacitor
 (C) Current controlled inductor (D) Voltage controlled inductor
41. What is the output waveform for the circuit shown if V_i is a sinusoidal waveform ?
 ($V_i = V_m \sin \omega t$)

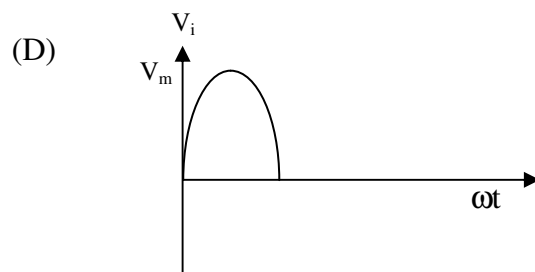
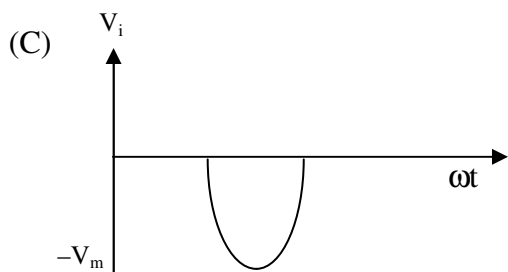
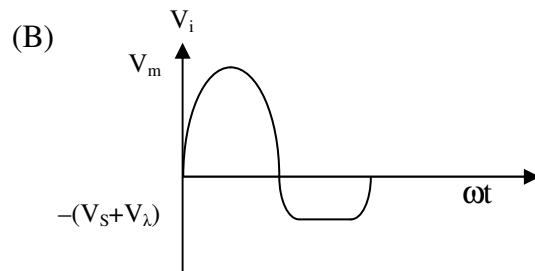
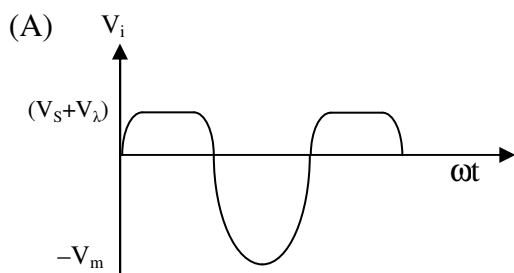
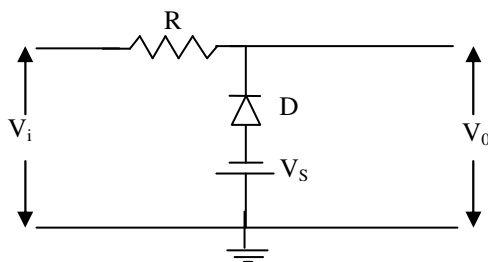

42. If both emitter-base and collector-base junctions of BJT are forward biased the transistor is in
 (A) Active region (B) Saturation region
 (C) Cut-off region (D) Inverse mode
43. The depletion region in semiconductor p-n junction diode has
 (A) Electrons and holes (B) Positive and negative ions on either side
 (C) Neither electron nor ion (D) No holes
44. In the circuit shown, for achieving good stabilisation we should have $[R_b = R_1/R_2]$

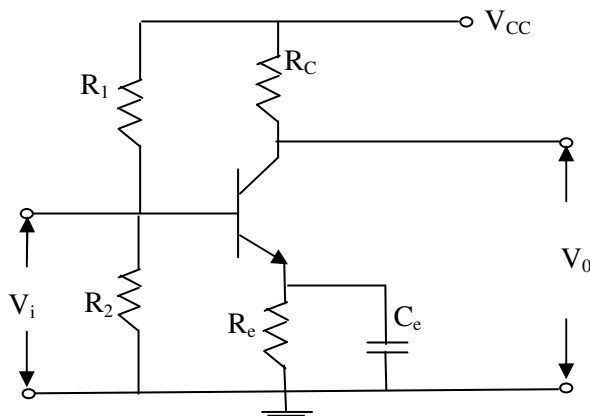

- (A) $\frac{R_e}{R_b} \ll 1$ (B) $\frac{R_b}{R_e} \ll 1$ (C) $\frac{R_b}{R_e} \gg 1$ (D) $\frac{R_b}{R_e} \cong 1$

45. For a transconductance amplifier the ideal values of input resistance (R_i) and output resistance (R_o) are
 (A) $R_i = \infty, R_o = 0$ (B) $R_i = 0, R_o = \infty$
 (C) $R_i = \infty, R_o = \infty$ (D) $R_i = 0, R_o = 0$
46. The parameters of a source follower are $g_m = 3 \text{ mA/V}$, $r_d = 30 \text{ k}\Omega$, $R_L = 3 \text{ k}\Omega$. Find the output impedance
 (A) $333 \text{ k}\Omega$ (B) $2.7 \text{ }\Omega$ (C) $3 \text{ }\Omega$ (D) $300 \text{ }\Omega$
47. An amplifier with midband gain $A = 500$ has negative feedback applied of value $\beta = 1/100$. Given the upper cut-off without feedback is 60 kHz with feedback it becomes
 (A) 10 kHz (B) 12 kHz (C) 300 kHz (D) 360 kHz
48. An oscillator circuit is mainly
 (A) DC to AC convertor (B) AC to DC convertor
 (C) DC to DC convertor (D) AC to AC convertor
49. The resolution of a 5-bit ADC is 0.32 Volts . For an analog input of 6.4 V , what is the output of the ADC ?
 (A) 10100 (B) 10010 (C) 10011 (D) 10001
50. D-FlipFlop is used as
 (A) Delay Switch (B) Divider circuit
 (C) Toggle Switch (D) Differentiator

51. The number of comparators in a 6-bit Flash ADC is
 (A) 63 (B) 64 (C) 6 (D) 62

52. For the logic circuit shown, the Boolean expression in its simplest form at the output A is

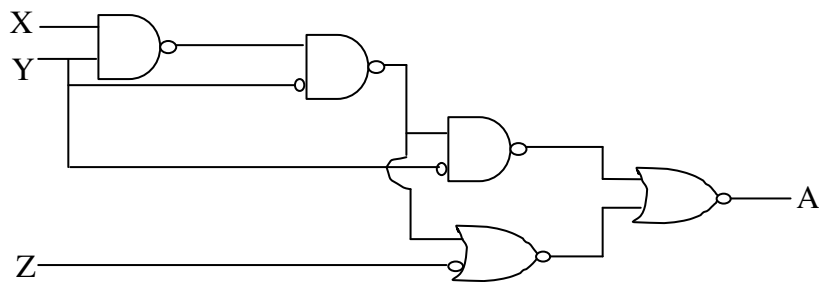

(A) $A=X$ (B) $A=Y$ (C) $A=Z$ (D) $A= X+Y$

53. The range of signed decimal numbers that can be represented by 5-bit is
 (A) -15 to +15 (B) -31 to +31 (C) -31 to +32 (D) -16 to +16

54. The non complement output Q_n of edge trigger JK-Flip-flop is 0. If $J=1$, what will be the state of output Q_{n+1}

(A) Cannot determined (B) Zero
 (C) One (D) Race around

55. Simplify the Boolean Expression to minimum literals $\bar{x}yz + xz$
 (A) $z(x + y)$ (B) $\bar{x}y$ (C) $y(x + z)$ (D) $\bar{z}(x + y)$

56. The minimum number of NAND gates required to implement $A + A\bar{B} + A\bar{B}C$ is equal to
 (A) 0 (B) 1 (C) 4 (D) 7

57. A carry look-ahead adder is frequently used for addition, because it
 (A) is faster (B) is more accurate
 (C) uses fewer gates (D) costs less

58. A 4-bit Mod-16 ripple counter uses a J-K flip-flop. If the propagation delay of each flip-flop is 50 ms, the maximum clock frequency is equal to
 (A) 20 MHz (B) 10 MHz (C) 5 MHz (D) 4 MHz

59. A divide-by-78 counter can be realized by using
 (A) 6 Mod-13 counters
 (B) 13 Mod-6 counters
 (C) 1 Mod-13 counter followed by 1 Mod-6 counters
 (D) 13 Mod-13 counters

60. The code used to reduce the error due to ambiguity in reading of a binary encoder is
 (A) Octal code (B) Excess-3 code
 (C) Gray code (D) BCD code

61. What is the maximum frequency of a clock pulse at which a 4 bit ripple counter operates reliably, with flip-flop delay of 40 ns and pulse width of strobe signal 25 ns
 (A) 5.8 MHz (B) 5.4 MHz (C) 6.2 MHz (D) 6.5 MHz
62. In standard TTL gates, the totem-pole output stage is primarily used to
 (A) Increase the noise margin of the gate
 (B) Decrease the output switching delay
 (C) Facilitate a wired-OR logic connection
 (D) Increasing the output impedance of the circuit
63. Fourier transform of 'A'
 (A) $2\pi A \delta(\omega)$ (B) $\pi A \delta(\omega)$ (C) $\pi A \delta(\omega) + \frac{A}{j\omega}$ (D) $\pi A \delta(\omega) + \frac{1}{j\omega}$
64. A signal of maximum frequency 20 kHz is sampled at Nyquist rate, and then the time interval between two successive samples is
 (A) 25 μ s (B) 2.5 μ s (C) 50 μ s (D) 20 ms
65. The convolution of x (t) and h (t) is given by $y(t) = \int_{-\infty}^{\infty} x(\tau)h(t - \tau)d\tau$, then
 (A) both x(t) and h(t) are causal (B) both x(t) and h(t) are non-causal
 (C) x(t) is causal and h(t) is non-causal (D) h(t) is causal and x(t) is non-causal
66. The Nyquist rate for the signal, $x(t) = 5 \sin 200 \pi t + 8 \cos 500 \pi t$ is
 (A) 200 Hz (B) 500 Hz (C) 700 Hz (D) 300 Hz
67. Aliasing occurs when the signal is
 (A) over sampled (B) under sampled
 (C) critically sampled (D) not sampled
68. A system is described by $H(z) = \left[\frac{(z+1)}{z(z-2)(z+2)} \right]$, the final value of the system is
 (A) 1 (B) -1/4 (C) -4 (D) ∞
69. The trigonometric Fourier series representation of a function with half wave symmetry consists of
 (A) cosine terms only (B) sine terms only
 (C) odd harmonics (D) even harmonics
70. The system characterized by the equation $y(t) = ax(t) + b$ is
 (A) linear for any value of b (B) linear if $b > 0$
 (C) linear if $b < 0$ (D) non-linear
71. The impulse response of a system is $h(n) = a^n u(n)$. The condition for the system to be BIBO stable is
 (A) 'a' is real and positive (B) 'a' is real and negative
 (C) 'a' > 1 (D) 'a' < 1

72. The DFT of a signal $x(n)$ of length N is $X(k)$. When $X(k)$ is given and $x(n)$ is computed from it, the length of $x(n)$
- (A) is increased to infinity (B) remains N
 (C) becomes $2N - 1$ (D) becomes N^2

73. The z transform of $x(n) = \sin \Omega n u(n)$
- (A) $\frac{z \sin \Omega}{z^2 - 2z \cos \Omega + 1}$ (B) $\frac{z \sin \Omega}{z^2 + 2z \cos \Omega + 1}$
 (C) $\frac{z \sin \Omega}{z^2 - 2z \cos \Omega - 1}$ (D) $\frac{z \sin \Omega}{z^2 + 2z \cos \Omega - 1}$

74. If $x_1(k) = 2^n u(k)$, $x_2(k) = \delta(k)$ and $x_3(k) = x_1(k) * x_2(k)$ then $X_3(\Omega)$ is given by
- (A) $\frac{1}{1 - 2e^{-j\omega}}$ (B) $\frac{1}{1 - 2e^{j\omega}}$
 (C) $\frac{1}{1 + 2e^{-j\omega}}$ (D) $\frac{1}{1 + 2e^{j\omega}}$

75. $\int_2^5 \delta(t - 6) dt =$
- (A) 1 (B) 0 (C) $\delta(6)$ (D) 3

76. The system having input $x(n)$ related to output $y(n)$ as $y(n) = \cos(x(n))$ is
- (A) causal, stable (B) causal, not stable
 (C) non-causal, stable (D) non-causal, not stable

77. Negative feedback in a closed loop control system does not
- (A) Reduce the overall gain (B) Reduce bandwidth
 (C) Improve disturbance rejection (D) Reduce sensitivity to parameter variation

78. If the unit step response of a system is a unit impulse function, then the transfer function of such a system is
- (A) 1 (B) s (C) $1/s$ (D) s^2

79. The transfer function $\frac{V(s)}{I(s)}$ in the signal flow graph shown in the figure is

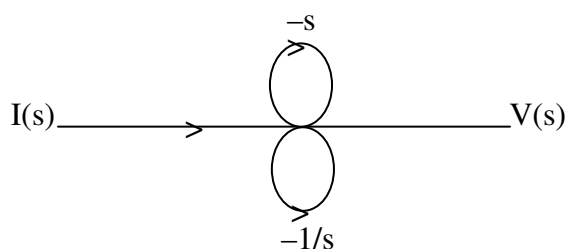

- (A) $\frac{s^2}{s^2 + s + 1}$ (B) $\frac{s^2 - s - 1}{s}$ (C) $\frac{s}{s + 1/s}$ (D) $\frac{s}{s^2 + s + 1}$

80. In a linear system an input of $5 \sin \omega t$ produces an output of $10 \cos \omega t$. The output corresponding to input $10 \cos \omega t$ will be equal to
 (A) $5 \sin \omega t$ (B) $-5 \sin \omega t$ (C) $20 \cos \omega t$ (D) $-20 \cos \omega t$
81. For a feedback control system of type 2, the steady state error for a ramp input is
 (A) infinite (B) constant (C) zero (D) indeterminate
82. If the characteristic equation of a system is $s^3 + 14s^2 + 56s + k = 0$ then it will be stable only if
 (A) $0 < k < 784$ (B) $1 < k < 64$ (C) $10 > k > 660$ (D) $4 < k < 784$
83. The impulse response of an initially relaxed linear system is $e^{-2t}u(t)$. To produce a response of $te^{-2t}u(t)$, the input must be equal to
 (A) $2e^{-t}u(t)$ (B) $\frac{1}{2}e^{-2t}u(t)$ (C) $e^{-2t}u(t)$ (D) $e^{-t}u(t)$
84. The transfer function $\frac{(1+0.5s)}{(1+s)}$ represents a
 (A) lead network (B) lag network
 (C) lag-lead network (D) proportional controller
85. The frequency at which the Nyquist diagram crosses the negative real axis is known as
 (A) gain crossover frequency (B) phase crossover frequency
 (C) damping frequency (D) natural frequency

86. Obtain the transfer function for the response shown below

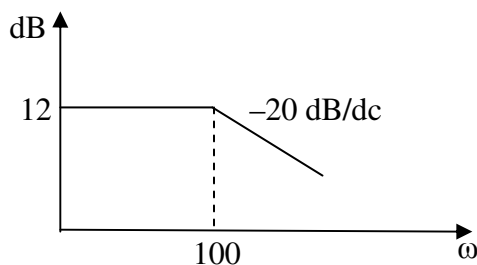

- (A) $\frac{40}{s(1+0.1s)}$ (B) $\frac{4}{s(1+0.1s)}$
 (C) $\frac{4}{(1+0.1s)}$ (D) $\frac{20}{(1+0.1s)}$
87. The open loop transfer function of a unity feedback control system is given by $G(s) = \frac{k(s+2)}{s(s^2+2s+2)}$, the centroid and angle of root locus asymptotes are respectively
 (A) Zero and $+90^\circ, -90^\circ$ (B) $-2/3$ and $+60^\circ, -60^\circ$
 (C) Zero and $+120^\circ, -120^\circ$ (D) $-2/3$ and -90° and $-90^\circ, +90^\circ$

88. Consider the following properties attributed to state model of a system :
1. state model is unique
 2. state model can be derived from the system transfer function
 3. state model can be derived from time variant systems
- (A) 1, 2 and 3 are correct (B) 1 and 2 are correct
(C) 2 and 3 are correct (D) 1 and 3 are correct
89. The term reset control refers to
- (A) proportional control (B) integral control
(C) derivative control (D) none of these
90. When zero-mean Gaussian process is given as input to LTI system, its output will be
- (A) Zero-mean Gaussian process
(B) Gaussian process but not necessarily zero mean
(C) Zero mean process but not necessarily Gaussian
(D) Depends on the nature of $h(t)$ of the system
91. Ring modulator is used to produce
- (A) DSB-SC (B) SSB (C) USB (D) VSB
92. Which one of the following modulations is non-linear?
- (A) Amplitude modulation (B) SSB
(C) Frequency modulation (D) Phase modulation
93. The noise figure of a super heterodyne receiver is mostly controlled by
- (A) the RF stage (B) mixer stage
(C) IF stage (D) detector stage
94. Companding is used in PCM to
- (A) Reduce Bandwidth (B) To maintain uniform S/N ratio
(C) Increase S/N ratio (D) Reduce Power
95. An SSB transmitter has a 24-V dc power supply. On voice peaks the current achieves a maximum of 9.3 A. What will be its Peak Envelope Power ?
- (A) 223.2 W (B) 2.5 W (C) 446.4 W (D) 61.9 W
96. Noise performance of PAM is
- (A) Better than direct base band transmission
(B) Poorer than direct base band transmission
(C) Better than CW amplitude modulation
(D) Poorer than CW amplitude modulation
97. Which one of the following digital modulation scheme is not preferred when the channel is non-linear?
- (A) QAM (B) BFSK (C) BPSK (D) MSK

98. In a 16-ary PSK, the symbol rate is 10 kbps. The bit rate is
 (A) 160 kbps (B) 40 kbps (C) 2.5 kbps (D) (10/16) kbps
99. The effect of atmospheric noise is most severe in
 (A) medium wave band (B) shortwave band
 (C) VHF band (D) microwave region
100. For M-ary PSK system the best trade-off between bandwidth efficiency and transmitted power is given for a value of M equal to
 (A) 2 (B) 4 (C) 8 (D) 16
101. The main advantage of TDM over FDM is that it
 (A) Needs less power (B) Needs less Bandwidth
 (C) Needs simple circuitry (D) Gives better S/N ratio
102. Which type of multiple access method is preferred in GSM Cellular systems?
 (A) FDMA (B) FDMA/TDMA (C) CDMA (D) SDMA
103. FDMA technology efficiency reduced because of
 (A) guard bands (B) adjacent channels
 (C) spectrum (D) bandwidth
104. Which of the following gives maximum probability error?
 (A) ASK (B) FSK (C) PSK (D) DPSK
105. Divergence theorem is applicable for
 (A) static field only (B) time varying fields only
 (C) both static and time varying fields (D) electric fields only
106. A wave is incident normally on a good conductor. If the frequency of a plane electromagnetic wave increases four times, the skin depth, will
 (A) increase by a factor of 2 (B) decrease by a factor of 4
 (C) remain the same (D) decrease by a factor of 2
107. In a travelling electromagnetic wave, E and H vector fields are
 (A) perpendicular in space (B) parallel in space
 (C) E is in the direction of wave travel (D) H is in the direction of wave travel
108. In a dielectric-conductor boundary (interface), the tangential component of electric field is
 (A) E_t (B) $2E_t$ (C) Zero (D) Infinity
109. For a transmission line terminated in its characteristic impedance, which of the following statement is incorrect ?
 (A) It is a smooth line
 (B) The energy distribution between magnetic and electric field is not equal
 (C) Standing wave does not exist
 (D) Efficiency of transmission of power is maximum

110. Transverse electric wave travelling in z- direction satisfies
 (A) $E_z = 0; H_z = 0$ (B) $E_z = 0; H_z \neq 0$
 (C) $E_z \neq 0; H_z = 0$ (D) $E_z \neq 0; H_z \neq 0$
111. Consider a transmission line of characteristic impedance 50 ohms and the line is terminated at one end by $+j 50$ ohms, the VSWR produced in the transmission line will be
 (A) +1 (B) zero (C) infinity (D) -1
112. Poynting vector gives
 (A) direction of energy flux density (B) direction of polarization
 (C) intensity of electric field (D) intensity of magnetic field
113. A hollow rectangular waveguide acts as a
 (A) High pass filter (B) Low pass filter
 (C) Band pass filter (D) Low frequency radiator
114. A very small thin wire of length $\lambda/100$ has a radiation resistance of
 (A) 0Ω (B) 0.08Ω (C) 7.9Ω (D) 790Ω
115. Double stub matching eliminates standing waves on the
 (A) Source side of the left stub (B) Load side of the right stub
 (C) Both sides of the stub (D) In between the two stubs
116. The characteristic impedance of a distortion less line is
 (A) Real (B) Inductive (C) Capacitive (D) Complex
117. The intersection of the constant-r circle with positive real axis gives the position of
 (A) average voltage on the line (B) minimum voltage on the line
 (C) maximum voltage on the line (D) RMS voltage on the line
118. In Rectangular Waveguide, the mode subscripts m and n indicate
 (A) Number of half wave patterns (B) Number of full wave patterns
 (C) Number of zeros of the field (D) Number of poles of the field
119. In a circularly polarized uniform wave, travelling in x-direction, the phase difference between E_z and E_y is
 (A) 30° (B) 90° (C) 45° (D) 180°
120. The velocity of an EM wave in a conductor when compared to a dielectric is
 (A) higher (B) lower
 (C) same velocity (D) cannot be decided

SPACE FOR ROUGH WORK